

Continuous Line

Standard Construction and Materials

FRAME: 4" deep exterior frame - .081" thick (nominal) extruded aluminum 6063-T52/T6 alloy.
2" deep interior frame - .063" thick (nominal) extruded aluminum, 6063-T52/T6 alloy.

BLADE: Exterior straight blades at a 37° angle, approximately 3 1/2" on centers. Interior chevron blades approximately 1 1/4" on centers.

LOUVER FACE: Full width sill with head and blades contained in jambs.

DRAIN SILL PAN: .060" thick (nominal) formed aluminum.

SCREEN: (When indicated, in a removable frame.)

1/2" flattened aluminum (.051" thick),

-or- 1/2" sq. mesh, intermediate double-crimped aluminum wire, .063" dia.,

-or- 19/16 mesh, .011" dia. aluminum wire, insect screen.

FINISH: Mill

Options

Finish - Baked Enamel, Kynar, Anodize

Notes

- 1/2" nominal deduction will be made to the opening size given.
- Louvers shall withstand a windload of 20 PSF for a single panel. Consult the factory to substitute other load requirements.
- Approximate shipping weight is 9.0 lbs./sq.ft.

Louver Sizes

Min Panel	Max Single Panel
12"W x 12"H	60"W x 96"H

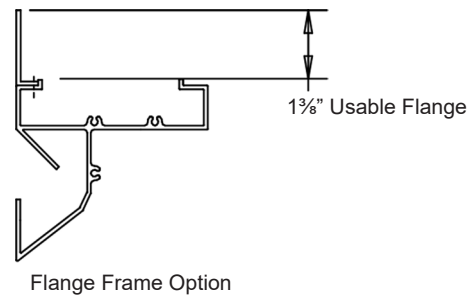
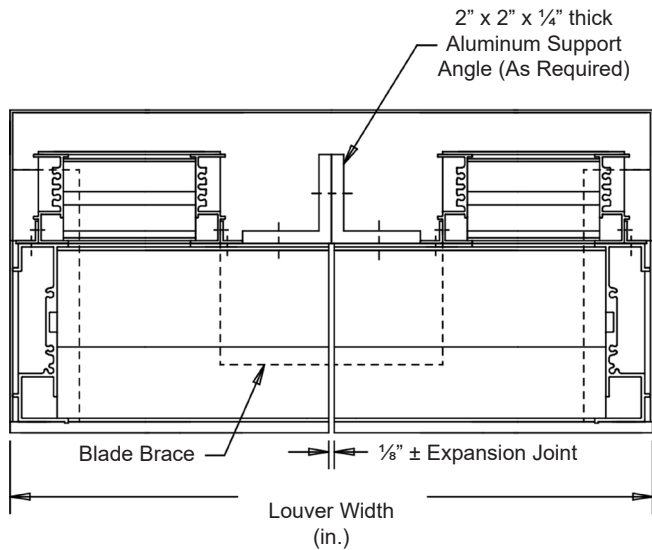
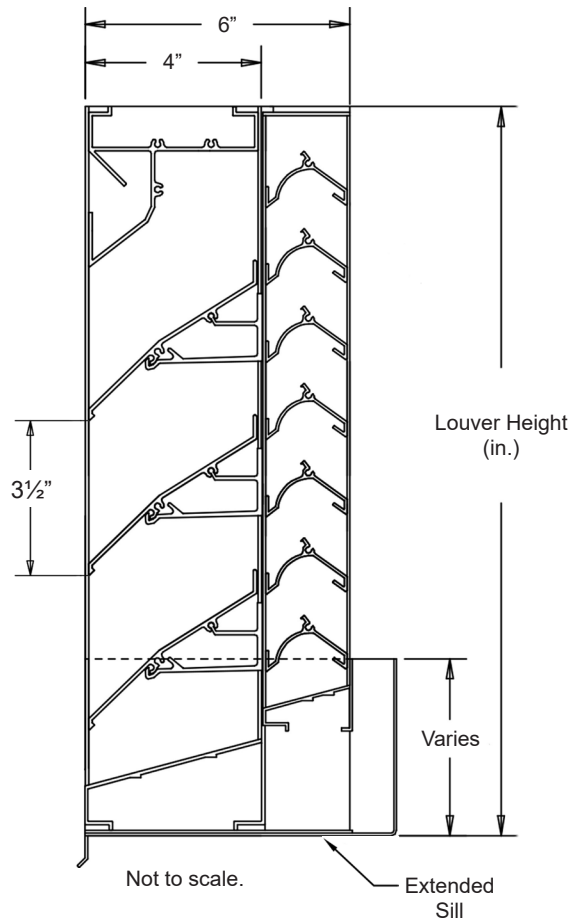

											
Item #	Qty	Width	Height	Width	Height	Mullion	Type	Location			
Arch. / Eng.:		Opening Size		Louver Size		EDR:	Screens		ECN:	Job:	
Contractor:						Date:	DWN:	DWG:			

In the interest of product development, Cesco Products reserves the right to make changes without notice.



450 Riverside Dr • Wyalusing PA, 18853
Phone: 570-746-1888 • Fax: 570-746-9286
www.cescoproducts.com

Performance Data

Pressure Drop: .160 in. w.g. at 1000 fpm (intake)

Free Area: 7.07 sq.ft. = 44.2% for 48"W x 48"H sample tested in accordance with AMCA Standard 500-L.

Class "B" Rating at 3 in. rain fall at intake velocity of 578 fpm (3,259 cfm) at wind speed of 29 mph.

Testing based on 48" x 48" sample size under AMCA Standard 500-L.

Ratings do not include effects of a screen.

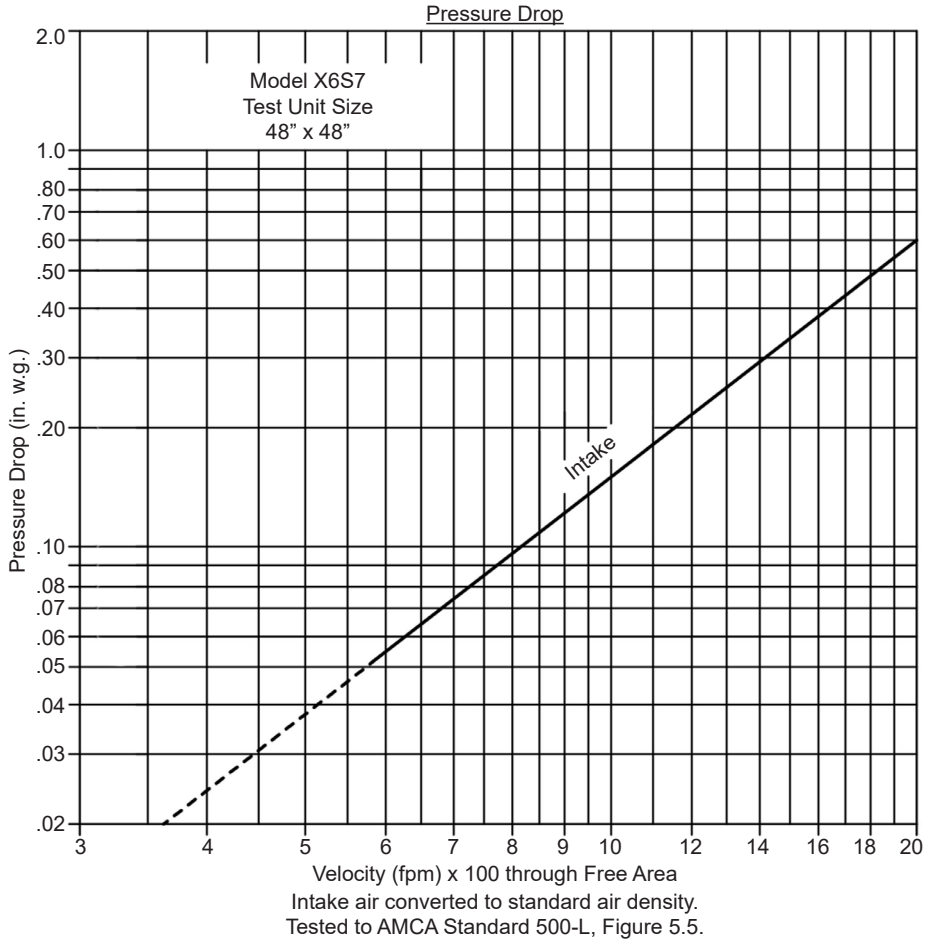

		Free Area (sq.ft.)								
		Width (in.)								
Height (in.)		12"	18"	24"	30"	36"	42"	48"	54"	60"
		12"	.17	.29	.40	.51	.62	.73	.84	.95
24"	.58	.96	1.33	1.70	2.08	2.45	2.82	3.20	3.57	
36"	.99	1.63	2.26	2.90	3.54	4.17	4.81	5.44	6.08	
48"	1.40	2.30	3.20	4.10	4.99	5.89	7.07	7.69	8.58	
60"	1.81	2.97	4.13	5.29	6.45	7.61	8.77	9.93	11.09	
72"	2.22	3.64	5.07	6.49	7.91	9.33	10.75	12.17	13.59	
84"	2.63	4.32	6.00	7.68	9.37	11.05	12.73	14.42	16.10	
96"	2.98	4.89	6.80	8.71	10.62	12.52	14.43	16.34	18.25	

Wind Driven Rainwater Penetration Test

Conducted to AMCA Standard 500-L.

Test size 1m x 1m (39.7" x 39.7") core area, nominal.

Louver Free Area 5.64 square feet.

Core Ventilation (m/s)	0.0	0.5	1.0	1.5	2.0	2.5	3.0	3.5	Rain Fall / MPH
FPM	0	136	187	303	379	475	577	686	3 in. / hr. rain fall and 29 mph Velocity
Free Area Ventilation (cfm)	0	1,469	2,013	3,259	4,080	5,110	6,215	7,382	
Free Area Velocity (fpm)	0	260	357	578	723	906	1,102	1,309	
Effective Rating Class	A	A	B	B	B	B	C	C	

Wind Driven Rain Penetration Classifications

Class	Effectiveness %
A	100 to 99%
B	98.9% to 95%
C	94.9% to 80%
D	Below 80%

Discharge Coefficient
Intake Cd= 0.33 (Class 2)

Discharge Loss Coefficient Classifications

Class	Discharge Loss Coefficient
1	0.4 and above
2	0.3 to 0.399
3	0.2 to 0.299
4	0.199 and below

Class 1 Loss Coefficient has the least resistance to airflow.

1. Core area is the front opening of a louver assembly with the blades removed.
2. Core area velocity is the airflow rate through the louver divided by the core area (39.37" x 39.37").
3. Free area is the minimum area through which air can pass. It is determined by multiplying the sum of the minimum distances between intermediate blades, top blade and head, bottom blade and sill, by the minimum distance between jambs.
4. Discharge loss coefficient is calculated by dividing a louver actual airflow rate vs. a theoretical airflow for the opening, providing an indication of the louver air flow characteristics.



Cesco Products certifies that the Model X6S7 shown herein is licensed to bear the AMCA seal. The ratings shown are based on tests and procedures performed in accordance with AMCA Publication 511 and comply with the requirements of the AMCA Certified Ratings Program. The AMCA Certified Ratings Seal applies to Air Performance and Wind Driven Rain Ratings only.